

electriciQ

USER MANUAL

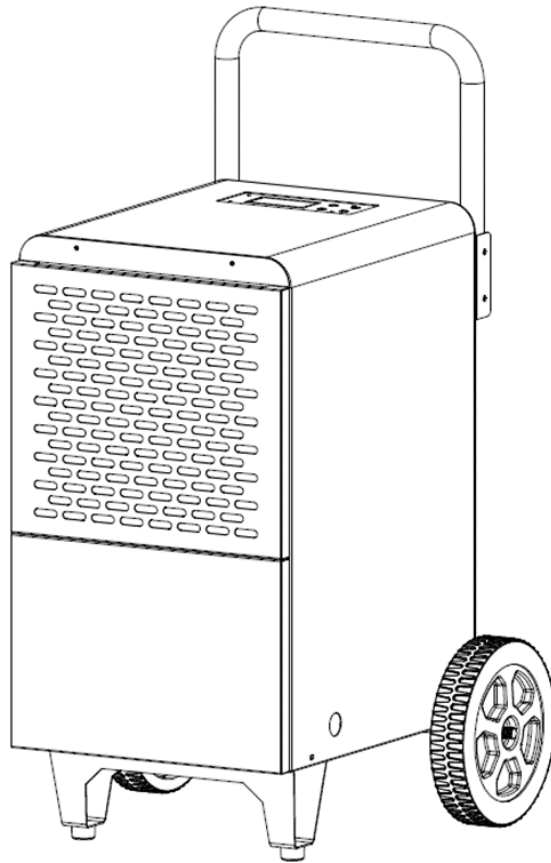

PORTABLE COMMERCIAL / INDUSTRIAL DEHUMIDIFIER

ECD30 30 Litres per day

ECD50 50 Litres per day

Thank you for choosing electriciQ.

Please read this user manual before using this innovative dehumidifier.

Please keep it safe for future reference.

Visit our page www.electriQ.co.uk for our entire range of Intelligent Electricals

CONTENTS

SAFETY	3
PARTS	5
FEATURES	6
PRODUCT OVERVIEW	6
POSITIONING THE DEHUMIDIFIER	7
ASSEMBLY	8
DRAINAGE OPTIONS	9
OPERATION	10
CARE AND MAINTENANCE	12
TROUBLESHOOTING	13
FREQUENTLY ASKED QUESTIONS	14
TECHNICAL SPECIFICATIONS	14
SUPPORT	15

SAFETY INSTRUCTIONS

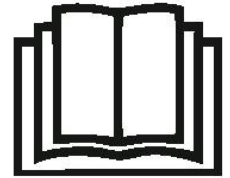

IMPORTANT

- Carefully read the instructions before operating the unit
- This appliance is for indoor use only and intended for use in a domestic environment only. Any other use is not recommended by the manufacturer and may cause fire, electrical shocks or other injury to user or property.
- Rating: This unit must be only connected to a 220-240 V / 50 Hz earthed outlet.
- Installation must be in accordance with regulations of the country where the unit is used.
- If you are in any doubt about the suitability of your electrical supply have it checked and if necessary, modified by a qualified electrician.
- This dehumidifier has been tested and is safe to use. However, as with any electrical appliance - use it with care.
- Disconnect the power before dismantling, assembling or cleaning.
- Avoid touching any moving parts of the appliance.
- Never insert fingers, pencils or any other objects through the guard
- This appliance is not intended for use by persons (including children) with reduced physical, sensory or mental capabilities. It is also not intended for use by those with a lack of experience and knowledge, unless they have been given supervision or instruction concerning the use of the appliance by a person responsible for their safety.
- Do not leave children unsupervised with this appliance.
- Do not clean the unit by spraying it or immersing it in water.
- Never connect the unit to an electrical outlet using an extension cord. If a power outlet is not available, one should be installed by a qualified electrician.
- Never operate this appliance if the cord, power adapter or plug is damaged. Ensure the power cord is not stretched or exposed to sharp objects/edges.
- A damaged power supply cord should be replaced by the manufacturer or a qualified electrician in order to avoid a hazard.
- Any service other than regular cleaning or filter replacement should be performed by an authorized service representative. Failure to comply could result in a voided warranty.
- Do not use the appliance for any purpose other than its intended use.
- Do not tilt the unit while in use. The unit is design to work only in vertical position.
- This dehumidifier must always be stored and transported upright, otherwise irreparable damage may be caused to the compressor; if in doubt we suggest waiting at least 24 hours before starting the unit.
- Avoid restarting the dehumidifier unless 5 minutes have passed since being turned off. This prevents damage to the compressor.
- Never use the plug as a switch to start or turn off the dehumidifier. Use the provided ON/OFF switch located on the control panel.
- Always place the unit on a dry and stable surface.
- The appliance should not be installed in laundry or wet rooms where the humidity is higher than 85% RH
- Do not dry laundry above the unit to prevent water entering the dehumidifier. Place the laundry at least 1 meter away from your dehumidifier.

- Before moving the appliance the water tank should be emptied and/or the drainage pipe must be disconnected.
- The appliance must be placed in a room without sources of ignition (for example: open flames, an operating gas appliance or an operating electric heater).
- R290 refrigerant gas complies with European environmental directives.
- R290 has a low GWP (Global Warming Potential) of 3.
- The ECD30 contains about 120g of R290 refrigerant gas.
- The ECD50 contains about 200g of R290 refrigerant gas.
- Do not use or store the appliance in an unventilated space with an area smaller than shown in the specification table per unit.
- If the appliance is installed, used or stored in an unventilated room, the room must be such as to prevent stagnation of possible leaks of refrigerant gas as there could be a danger of fire or explosion should the refrigerant come into contact with electric heaters, stoves or other sources of ignition.
- Refrigerant gas may be odourless.
- Do not use the product and contact the retailer for advice, if damage has occurred to the unit which may have compromised the refrigerant system.
- Any repairs or maintenance must only be carried out on the unit by a suitably qualified engineer. Before opening and servicing the unit the authorized engineer must be in possession of a copy of the manufacturer's service manual and must follow the safety information contained within it to ensure all hazards are minimized.
- The refrigerant system should not be perforated or punctured.
- Do not place the unit next to heat sources (e.g. electrical fires, fireplaces, etc.)
- Avoid mishandling the dehumidifier. Dropping, throwing the unit can cause damage to its internals and increases the risks of operating it.
- Do not store or use gasoline, petrol, paint, solvents or other flammable vapours or liquids in the vicinity of this dehumidifier or any other appliance.
- This dehumidifier must not be used in spaces where there is a high concentration of gases, solvent or other volatile organic compounds; in very dusty environments; in any domestic, commercial or industrial environment where the air composition is flammable.

ENERGY SAVING AND UNIT SAFETY PROTECTION TIPS

- Do not cover or restrict the airflow from the outlet or inlet grills. Do not operate and follow troubleshoot procedure if the self-opening louvers do not open on power on.
- For maximum performance the minimum distance from a wall or objects should be 20 cm
- Keep the filters or grills of the unit clean. Under normal conditions, filters or grills should only need cleaning once every three weeks (approximately).
- Since the filters remove airborne particles, more frequent cleaning maybe necessary, depending on the air quality. Vacuum both mesh and optional carbon filters and wash the mesh filters with hot soapy water and dry them before placing them back in the unit.

VISUAL SAFETY GUIDE ON WHERE OR WHEN NOT TO USE YOUR DEHUMIDIFIER

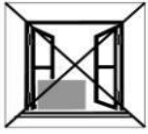

Exposed to the weather outdoors



Near water



If the power cable wires are frayed or cut



Where small children may be left unattended



If an extension lead may become overloaded



Where the power cable may be damaged



On a slope or uneven surface



Where there is risk of fire or close to a naked flame

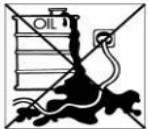

Where it may be damaged by chemicals



Where there is a risk or interference by foreign objects



This product is not made for DIY repair



If there is a risk of water falling on the unit

PARTS



Bolts (For Axle) x 4



Bolts (For Handle) x 4



1m Flexible Water Pipe x 1



Nuts (For Wheels) x 2



Washers (For Wheels) x 2

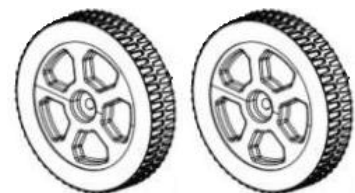

Wheels x 2

FEATURES

The ECD range of dehumidifiers use compressor technology to extract water from the environment. Compressor dehumidifiers are ideal for environments which are heated during the winter months and maintain a temperature above 12-15°C, although these units can be used un temperatures down to 5°C. The dehumidifiers are easy to move around and are designed to extract unwanted humidity. They feature an intelligent humidistat where the desired relative humidity can be adjusted in increments of 5% between 10%* and 95% ensuring your room is not dried too much and power is not wasted.

FEATURES

Your dehumidifier belongs to the electriQ dehumidifier range featuring power saving logic.

1. Easy to use controls
2. Cost effective way to combat mould, condensation and damp
3. Wheels for improved mobility
4. Intelligent CPU controlled digital humidistat with 10*-95% RH and room humidity display
5. 24 hours start / stop timer
6. Tank operation or permanent drainage option with splash proof tank
7. Tank full alarm & auto-stop function
8. Auto restart

* Although the desired humidity can be set as low as 10%, lower settings will act as a continuous mode, as they are unlikely to be achievable in the UK.

PRODUCT OVERVIEW

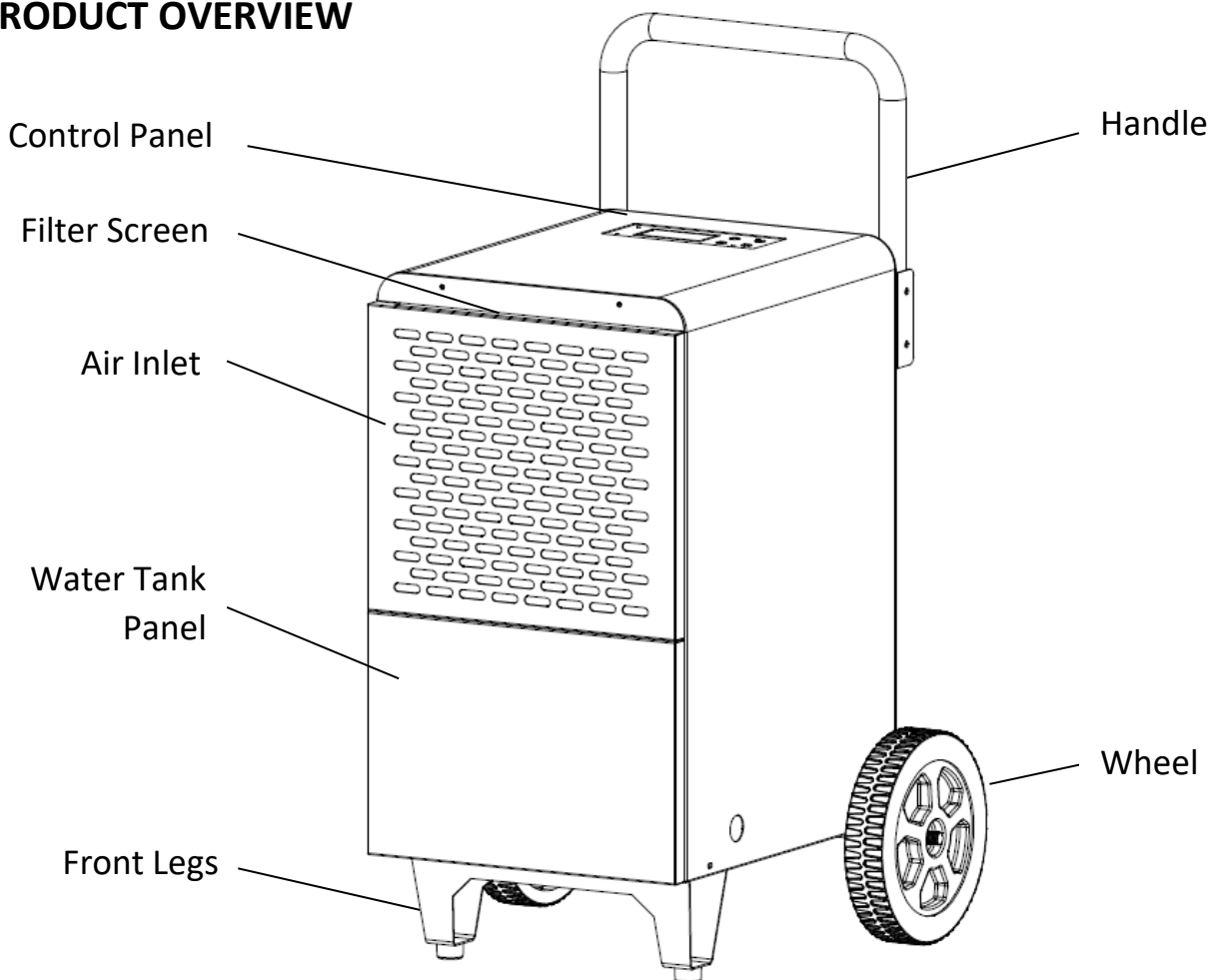

POSITIONING THE DEHUMIDIFIER

A badly positioned dehumidifier will have little effect. In positioning the dehumidifier please ensure circulation of air is not restricted around the unit.

Allow at least 50 cm space to the sides and back of the unit, and 100cm to the front. This dehumidifier is designed only for indoor applications.

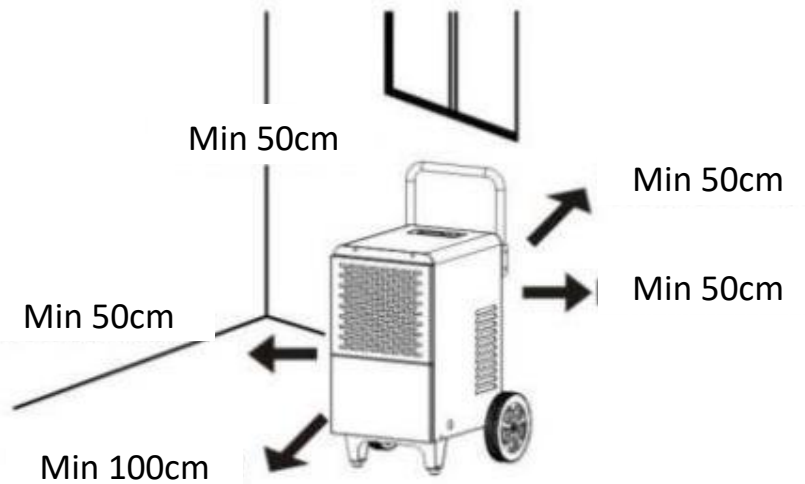

Use in an enclosed area for maximum efficiency. Close all doors, windows to create an effective operating environment.

Your electriQ dehumidifier will extract water from the air, protecting your space from the harmful effects of excessive moisture as soon as it is turned on. Excess moisture is dispersed throughout your home. For this reason, the dehumidifier should be positioned in a central and clear location so that it can draw this moist air towards it from all over the home. A warm hallway or landing is an excellent position for your dehumidifier. If possible, leave interior doors ajar to allow air circulation.

Alternatively, if you have a serious problem in one area you can begin by positioning the dehumidifier there and moving it to a more central location at a later date. For the most effective use, run your dehumidifier with external doors and windows kept closed. Please note the unit should not be placed directly against a radiator or other heat source.

When positioning your electriQ dehumidifier, ensure that it is placed clear of any obstacle that may limit the air movement. Place the dehumidifier on a flat dry surface.

Note: Do not move the unit with water in the tank as it may tip over and spill water.

ASSEMBLY

The appliance must be fully assembled before plugging in. In order to prevent damage to the compressor, after assembly the unit must be left in an upright position for 2 hours before plugging in.

ATTACHING THE WHEELS

1. Attach the Axel to the base of the appliance using the 4 bolts provided.
2. Fix the wheels onto each end of the axel using the supplied washers and nuts, ensuring that they are secure.
3. Turn the appliance upright, and stand on the wheels.

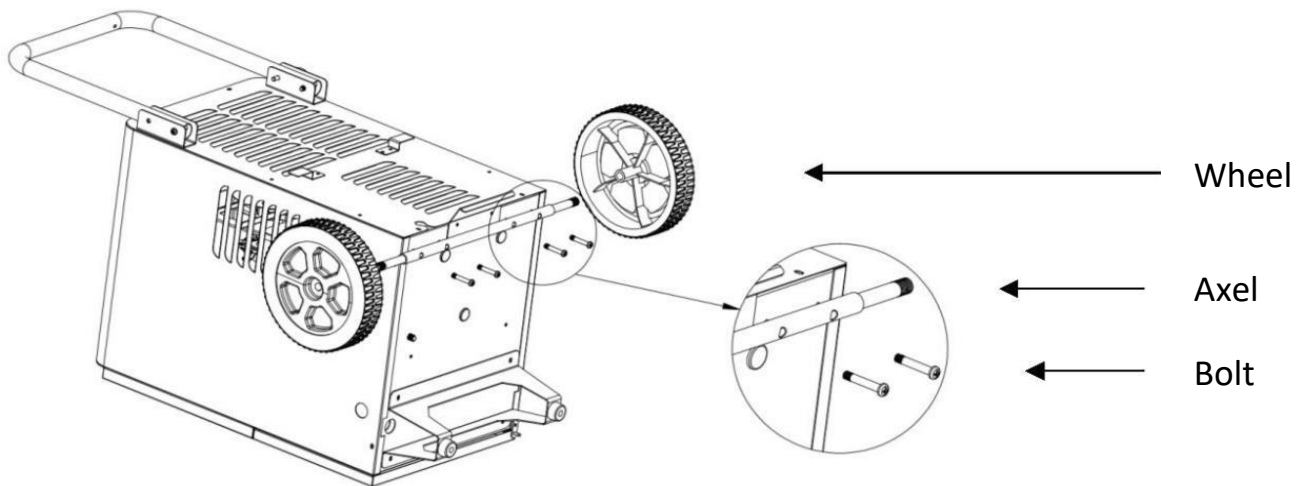

ATTACHING THE HANDLE

The handle is supplied resting against the rear of the unit for transportation. Unfold the handle so it is in the upright position and secure using the two bolts provided.

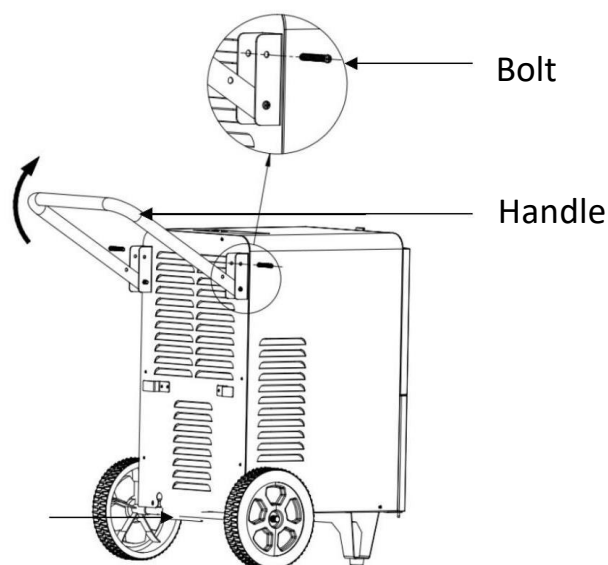

DRAINAGE OPTIONS

INTERNAL WATER TANK

The models are provided with a 7 Litre removeable water tank. When the water tank is full, the machine will automatically shut down and enter standby. The display will show the TANK FULL icon and an alarm will sound. Once the water tank has being emptied and put back into position, the dehumidifier can restart operation.

CONTINUOUS DRAINAGE

This range of dehumidifiers can be set up for continuous drainage. They use gravity fall to dispose water hence the drain should be lower than the dehumidifier water outlet. Be sure to run the water pipe downward and let the water flow out smoothly. Do not kink or bend the pipe. The drain pipe can be used in conjunction with an external uplift pump when the units are used in a cellar or similar low level applications.

Use a flexible pipe with a 12mm internal diameter. Remove the drain plug from the pipe connector on the base of the water tank. Route the pipe through the hole in the side of the unit.

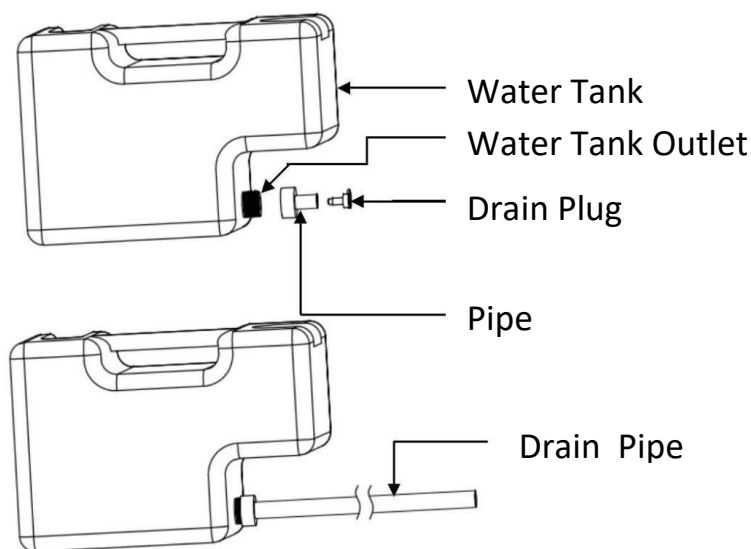

OPERATION

NOTES:

- The recommended humidity for a standard room is within the range of 50% to 70%, provided no special requirements are made.
- Although the desired humidity can be set as low as 10%, lower settings will act as a continuous mode, as they are unlikely to be achievable in the UK.

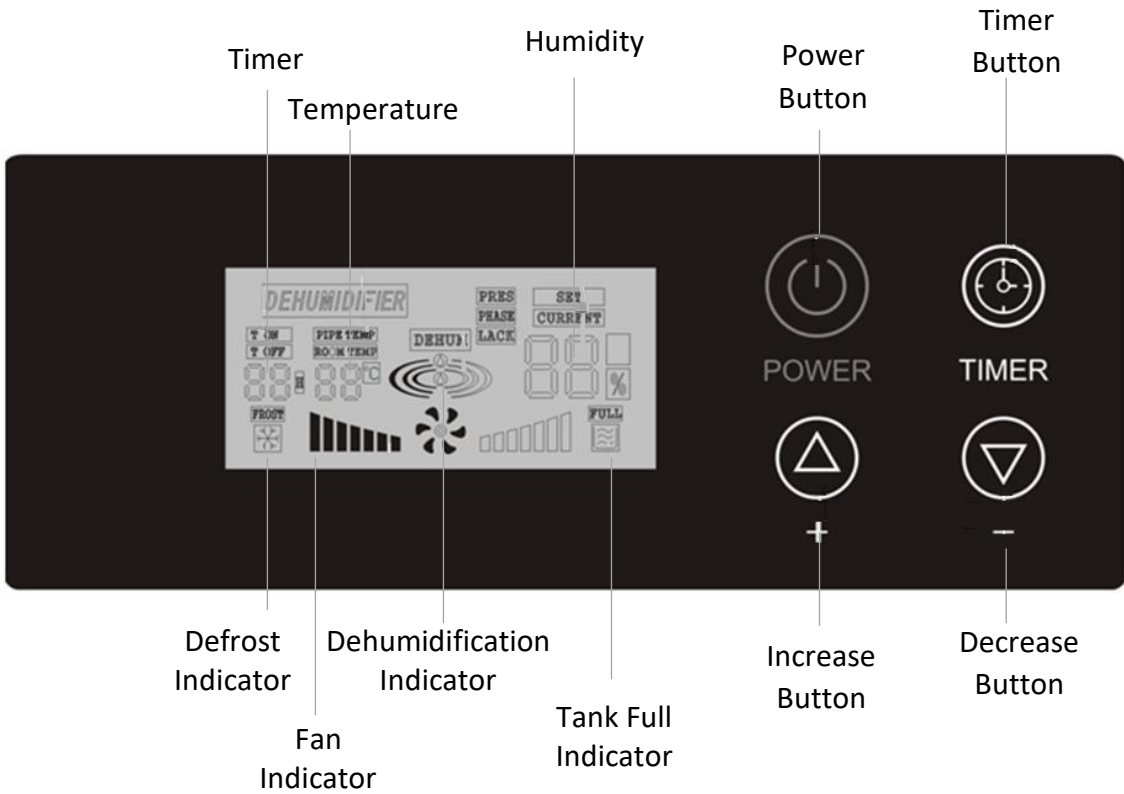

Press once to turn the unit on. Press again to turn the unit off.



Increase the desired humidity between 10% and 95%RH.
Also used to adjust the timer duration following pressing the TIMER button



Decrease the desired humidity between 10% and 95%RH.
Also used to adjust the timer duration following pressing the TIMER button



Press the timer button to activate the timer. Use the UP and DOWN buttons to adjust the timer duration (00-24hr).
The timer can be used in standby mode to specify in how many hours the unit will turn on, or while the unit is operating to specify in how many hours the unit will turn off.

Note: The layout may vary slightly between models.

WATER TANK FULL

The dehumidifier will display the TANK FULL symbol, bleep, and enter standby mode when the water tank is full. To resume operation the water tank should be emptied and reinserted into the unit.

If this happens when the unit is set up with continuous drainage, it indicates either a blockage of the drain pipe, or that the pipe is not going downhill. Check the route of the drain pipe to resolve the error.

AUTO DEFROST

When frost builds up on the evaporator coils, the compressor will cycle off and the unit will go in to defrost mode. Following completion of the defrost mode, the unit will return to the previously operating settings.

DEFROSTING MODE	DESCRIPTION	
Automatic defrosting	Sensor at normal state	This mode is entered when the compressor runs constantly for 30 min and the coil temperature is $\leq -1^{\circ}\text{C}$. In defrost mode the compressor stops running, the fan continues running and the defrosting light is on.
Timing defrosting	The unit defrosts for 8 minutes	

Note: When the ambient temperature is low, the appliance will enter defrost mode more often

HUMIDITY CONTROL

When the unit reaches the desired humidity set, both the fan and compressor will shut down; and when the humidity of the room is above the desired level both fan and compressor will operate.

If the room humidity displayed appears to be incorrect, it can be adjusted by following the below:

1. In standby mode, press and hold the TIMER Button for over 10 seconds.
2. Both the Set Humidity and Current Humidity symbol will flicker and the humidity display will show the current humidity
3. Use the UP and DOWN buttons to adjust the humidity reading.

FAULT PROTECTION

The intelligent logic within the unit will monitor the performance of the refrigerant circuit. If after 10 minutes the temperature of the cold coil within the unit has not reduced sufficiently, the unit will enter standby mode and "PRESSURE HOLDING" will be displayed on the control panel. The unit will not operate until the fault has being rectified.

CARE AND MAINTENANCE

Always shut off the unit and unplug it from the mains before cleaning or performing any maintenance. When it is not in use for long periods, it is advisable to remove the plug from the power socket. Do not use chemical solvents (such as benzene, alcohol or gasoline) as they may cause irreversible damage to the unit.

CLEAN THE AIR INLET

The Air-inlet may gather dust easily, please clean it often with a soft, damp cloth. If the filter is covered by dust, the airflow and the performance of the unit will be affected, it may even cause damage to the unit. We recommend that you regularly clean the filters. The dehumidifier must be disconnected from the socket before maintenance and the filters must be allowed to fully dry before re use.

1. Remove the filters from the unit, and tap the dust away.
2. cleaner or soft-brush.
3. If dirt and grease is accumulated wash the mesh filter in hot soapy water.
4. Replace the filters in position as shown in the diagram.
5. Never use the unit without the antibacterial mesh dust filter.

CLEAN THE GRILLE AND CASE

Use water and a mild detergent to clean the washable mesh filters. Do not use bleach or abrasives. Do not splash water directly onto the main unit. Doing so may cause an electrical shock and can lead to the insulation to deteriorate, or cause the unit to rust. The air intake and outlet grilles get soiled easily, so use a vacuum attachment or soft brush to clean. Wipe the dehumidifier body with a soft damp cloth or kitchen towel.

CLEAN THE WATER TANK

Every few weeks, clean the tank to prevent the growth of mould, mildew and bacteria. Partially fill the tank with clean water and add a little mild detergent. Swish it around and then empty the tank and rinse.

NOTE: Do not use a dishwasher to clean the tank. After cleaning and drying, the tank must be reinserted securely into dehumidifier in order to restart operation.

END OF SEASON MAINTENANCE

1. Empty and clean the water tank.
2. Clean the unit and the filter as per cleaning procedure above.
3. Cover the unit and keep it in a dry place.

CAUTION:



- When not in use, the user should switch the unit off by pressing the Power button so that the indicator LED is turned off, before unplugging it from the mains.
- Always follow the safety instructions outlined at the beginning of the user manual.
- Disconnect the dehumidifier from the mains if the unit is not in use.
- To prolong the life of the dehumidifier, do not use for long periods of time without disconnecting the unit from the power supply.

TROUBLESHOOTING

Issue	Cause	Solution
Hot or cold air being produced	Normal Operation	When the unit is in dehumidifying mode it absorbs humid air from room and freezes it to reduce the humidity. During the cold cycle there should be cold air coming out of the unit During the defrost cycle hot dry air should be coming out of the outlet grill.
Unit does not operate	Is the plug properly inserted in the socket?	Insert the plug into the socket and turn the switch on.
	Does the tank full indicator is red?	Tank full, float displaced or tank not properly inserted. Empty tank, check float and make sure tank is properly inserted in unit.
Dehumidifier does not extract water	Is the unit set to a humidity level lower than the one in the room?	Set the humidity level on the humidistat below current humidity reading.
	Is the temperature too low for water extraction to be efficient?	Increase temperature in the room or reposition the unit.
	Is any intake grill or discharge blocked? Is the unit too close to walls.	Remove obstructions and restart the unit. Ensure a distance of at least 50 cm between the unit & walls
Airflow seems weak	Is filter dirty or clogged?	Please service the filters regularly as per user manual.
Unit is noisy during operation	Is the unit on an uneven surface?	Please place on flat horizontal surface.
	Is filter clogged?	Please service the filters regularly as per user manual.
Unit leaking	Is it on a flat surface?	Ensure the unit is on a flat surface.
	Is the drain pipe obstructed.	Check the route of the drain pipe to ensure it is not constricted or travelling uphill.
E2/E3 Error Code	Humidity / Temperature sensor error	Use the unit within the prescribed temperature range. Unplug the unit, rest and plug it back in. If error repeats, call for service centre.
EE Error Code	Refrigerant Leakage	Leave the unit to rest for at least 3 hours, with the room well ventilated before attempting to restart. If this does not resolve, contact the service centre.

Any other malfunctions will need to be reported to electriQ service centre. Do not attempt unauthorised repairs as these may invalidate the warranty.

TECHNICAL SPECIFICATION

Model	ECD30	ECD50
Power Supply	AC 220-240V/50Hz	
Dehumidifying Capacity	30L/Day (30°C RH80%)	50L/Day (30°C RH80%)
Power	500W	900W
Rated Current	2.3A	4.0A
High/Low Pressure	2.5/1.0Mpa	
Desired Humidity Range	10* to 95%	
Tank Capacity	7 Litres	
Drainage Pipe Internal Diameter	12mm	
Maximum uplift of condensate	N/A	
Product Dimensions (mm)	480x450x655	480x450x655
Weight (Kgs)	26	30
Refrigerant	R290, 120g	R290, 200g
Minimum room area (M ²)	6	10
Global Warming Potential	3	
Operating environment	5°C ~ 35°C	
 		

* Note: Although the unit can be set to very low desired humidity levels, levels below 40% are unlikely to be achievable in most circumstances, and as such acts as the unit being set to run continuously.

FREQUENTLY ASKED QUESTIONS

Why doesn't the dehumidifier seem to extract much water if the temperature is low?

This is a compressor dehumidifier which works best in temperatures above 15°C. If the temperature is low and the air is dryer than the setting on the humidistat the unit will not extract water. If you want to use a dehumidifier for outside buildings, unheated properties, boats or garages please check our desiccant range.

Why doesn't the unit work /or stops suddenly?

The water tank may be full or displaced. To rectify: empty the tank and carefully place the tank back in the unit. Also the unit may be running in dehumidifying mode with a low room temperature. Please check if the room temperature is lower than 5°C. If so, the unit will stop working while in dehumidifying mode. (unit may be defrosting).

The ambient operating range is between 5°C and 35°C with a relative humidity ranging from 30% to 80%. For maximum efficiency use the unit between 15°C and 32°C.

Sometimes cold and/or hot air comes out from the air outlet grill, why?

When the unit is in dehumidifying mode it absorbs humid air from room and freezes it to reduce the humidity. During the cold cycle there should be cold air coming out of the unit. During the hot cycle hot dry air should be coming out of the outlet grill.

ENVIRONMENTAL PROTECTION

Disposal: Do not dispose this product as unsorted municipal waste. Collection of such waste must be handled separately as special treatment is necessary.



Recycling facilities are now available for all customers at which you can deposit your old electrical products. Customers will be able to take any old electrical equipment to participating civic amenity sites run by their local councils. Please remember that this equipment will be further handled during the recycling process, so please be considerate when depositing your equipment. Please contact the local council for details of your local household waste recycling centres.

electriQ UK SUPPORT

www.electriQ.co.uk/support

Please, for your own convenience, make these simple checks before calling the service line.

If the unit still fails to operate call: 0330 390 3061 or complete the online form

1. Have you emptied the water tank before resuming operation?
2. Is the unit plugged into the mains? Does the power adapter works?
3. Is the fuse in the power plug OK?

Office hours: 9AM - 5PM Monday to Friday

www.electriQ.co.uk

Unit J6, Lowfields Business Park
Lowfields Way, Elland
West Yorkshire, HX5 9DA